

Larox High Pressure Knife Gate Valve (LKH)

Larox Heavy Duty High Pressure Knife Gate Valve is built with a cast body and features a heavy-duty stainless steel gate. Removable seats on either side of the blade provide a bi-directional bubble tight seal, with no metal parts in contact with the slurry. LKH is available with pressure rating up to 20 bars.



Valve Operation

In the open position the two sleeves seal against each other in the centre of the valve, providing a full bore through which the slurry can travel without being in contact with any metallic components. Closing the valve forces the gate progressively down between the two mating sleeve ends until it reaches the fully closed position, at which point the sleeves seal tight against either side of the gate, effectively sealing and completely containing the line pressure. Any material/medium discharged between the sleeves during stroking open or closed is collected within the containment area of the valve body and drained via the multiple flushing ports in the body.

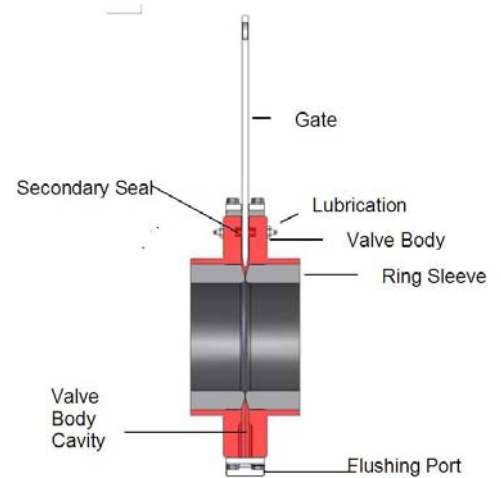

Features

- Double seat design for heavy duty slurry service.
- Easily replaceable ring sleeves.
- Full bore.
- When open, the knife-gate is fully withdrawn from the slurry flow.
- No metal parts in contact with the flowing slurry.
- Bubble tight shutoff.
- No clogged bonnet to impede flow.
- External epoxy coated.
- Easily adapted to suit most actuators
- Low maintenance requirements.
- Suitable for wet or dry service.
- Bi-directional flow.
- No packing gland to maintain.
- Wide range for elastomer available.
- No seat cavity where solids can collect and prevent full gate closure.

Valve Body

- Heavy duty cast body
- Heavy duty yoke frame
- Lubrication ports
- Flushing ports
- Open/closed lockout brackets standard.

Actuators

- Manual
- Manual gear
- Pneumatic
- Hydraulic
- Electromechanical

How the rubber ring sleeves work

Matching rubber ring sleeves are placed in the valve housing to seal against the gate when the valve is closed and seal against each other when the valve is open. This tight seal contains the high internal line pressure. Double seated design provides bi-directional flow and tight shut off..

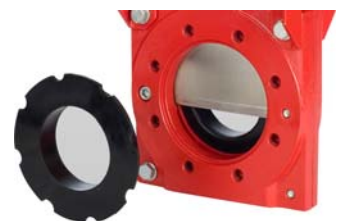

Product Specification

Body:

Wafer pattern SG Iron as standard.

Elastomer Sleeves:

NR (Standard) Nitrile, others on request

Pressure Rating:

20 Bar, standard (300 psi)

Diameter

80-600 mm

Gate Material:

316 Stainless Steel with optional wear coatings. Various blade materials optional.

Stem protection as standard

Drilling patterns:

DN80 to DN600 drilled and Tapped DIN, ANSI Other in request.

Flushing port as standard

Material Certification:

Certified chemical and physical test reports can be supplied

Applications

- Mining and metal industries
- Mineral processing
- Power generation
- Sand and gravel
- Chemical
- Pulp and paper
- Water and Wastewater treatment

Accessories

- Limit Switches
- Solenoid valves
- Gate guards

Secondary Seal

The field replaceable elastomer secondary seal replaces conventional gland packing, providing both wiping and lubricating actions to the blade as it strokes – via contact between the blade surface and the silicone grease filled contours of the seal itself. Lubrication of the blade allows for easier actuation and movement. There is no need to remove the valve from the line when replacing the secondary seal.

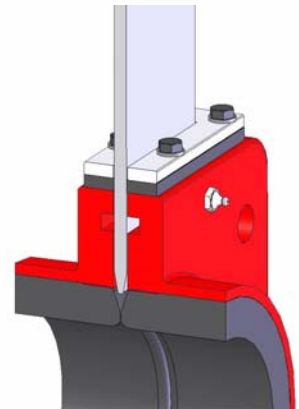

Dimension and weights

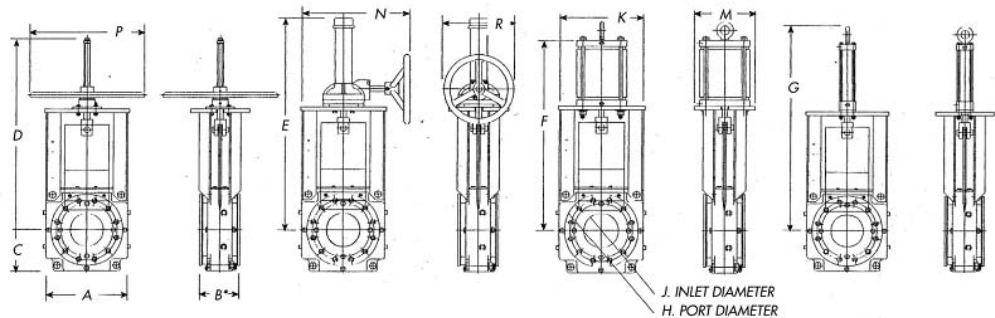

Valve																Valve Weight (KG)			
	A	B	C	D	E	F	G	H	J	K	M	N	P	R	HW	BG	AC	HC	
80	266	175	133	500	579	408	595	61	71	268	176	422	300	300	30	60	50	60	
100	298	181	150	692	718	768	768	85	98	320	232	449	300	300	40	70	60	70	
150	362	184	184	852	928	776	928	146	148	363	262	476	500	500	50	80	70	80	
200	425	184	215	1004	1033	994	1099	186	199	444	340	606	500	500	60	100	90	100	
250	495	226	250	-	1207	1197	1289	231	248	449	431	650	500	600	90	130	120	130	
300	558	242	279	-	1360	1300	1417	273	291	449	431	650	-	600	-	200	150	200	
350	673	251	352	-	1539	1400	1500	317	337	450	431	650	-	600	-	250	200	250	
400	825	286	393	-	1690	1650	1650	361	374	482	479	675	-	700	-	280	240	280	
450	882	311	419	-	1797	1924	1924	381	431	482	479	675	-	700	-	399	350	399	
500	946	373	450	-	2036	1993	2111	421	469	584	481	780	-	700	-	490	420	490	
600	1130	373	546	-	2269	2269	2335	538	576	584	481	780	-	700	-	550	500	550	

Dimensions are for guidance only – detailed dimensions drawings available on request. All dimensions are in millimeters, unless stated.

LAROX FLOWSYS OY

P.O. Box 338, FI-53101 Lappeenranta, Finland
 Tel. +358 201 113 311, Fax +358 201 113 300
 info@larox.fi, www.larox.fi