

SWE Exacta Series

Hydraulic diaphragm pumps with mechanical return mechanism



API 675 Hydraulic Diaphragm Metering Pumps

Metering pumps can be considered an irreplaceable instrument that allows the transfer, measure and control of liquids in a process.

Customers requirements to meet with a broad variety of applications, along with economical considerations, led us to the design of modular systems of pumps.

The **SWE Exacta Series** pumps of **SEKO** can be assembled to match nearly any dosing and budget requirement with our standard executions.

Should a special execution not to be included in our standard manufacturing program, the experience of more than 40 years gives us the know-how to design customized solutions.

Mechanism EXACTA® E Exacta Series



The mechanisms of the **E Exacta Series** have been designed conforming to **API 675 Standards**. Three sizes of increasing power are available. Oil bath lubricated, very compact and rugged, designed for continuous and heavy-duty operations.

The stroke length is adjustable from zero to the maximum manually or, on request, by means of an electric servomotor or pneumatic positioner; the set adjustment can be read on a dial indicator.

Multiheaded units can be assembled by combining mechanism of the same or different sizes. Gearboxes are available with different reduction ratios for an accurate selection of the performances.

Steady state accuracy, repeatability and linearity: in accordance with API 675 standards.

Flexibility:

Assembling of mechanisms of the same or different sizes.

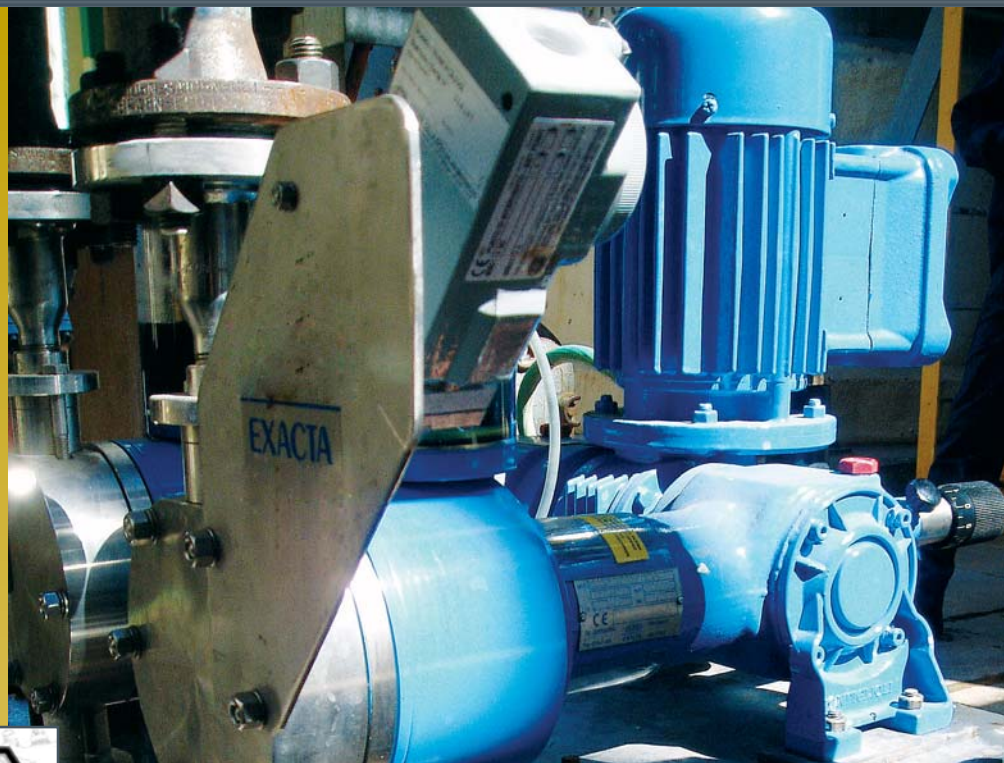

Drive

The standard execution includes the coupling to an electric motor at fixed or variable speed or flame proof execution. **Other options:** NEMA Standards motors, D.C. motors, mechanical speed variators, frequency converters (VCD).

Stroke length adjustment

It operates at pump running or at rest and includes a blocking device suitable to fix the selected flow rate.

Manual adjustment:

The clockwise allows the continuous stroke adjustment with the pump running or at rest. A blockage system fixes the rated flowrate.

Actuator:

Control signal: IN/OUT signal 4÷20 mA.

Profibus® signal available.

It includes include few non common characteristics such as: stroke limiters, overload protection, feed back signal, position indicator, flame proof execution; any component to be installed inside the control panel.

Pneumatic positioners:

Control signal: 0,2÷1 bar (3÷15 p.s.i.)

Profibus® signal available.

Option: I/P converter from 4÷20 mA to 0,2÷1 bar (3÷15 p.s.i.)



The “Exacta” Solution For Your Dosing Demands...

SW Pumphead

Hydraulic diaphragm pumpheads represent the ideal and sealed solution when transferring toxic or dangerous liquids that could pollute the environment or when the liquid pumped should be protected from external contaminations.

Operating principle

The diaphragm is hydraulically balanced between the process liquid and the hydraulic fluid and separates the hydraulic liquid from the ambient. The plunger reciprocating movement displaces the hydraulic fluid causing the movement of the diaphragm and an equal displacement of the process liquid. A device integrated in the hydraulic fluid protects the pumphead and ensures the reliability of the system: the pressure limiting valve (VSR) protects the pump from unexpected overpressures; the double diaphragm, **twin** type, is fitted with a control device “**EFD**” (Early Failure Detector) which gives the immediate signalling of the rupture of one diaphragm while the pump operation can continue until the maintenance can be scheduled.

- **Zero leakage:** hermetic (sealed) system
- **Double barrier:** the two layers “twin” diaphragm is fitted with a reliable control system (EFD) with local pressure gauge
- **Protected:** built-in overpressure valve
- **Totally sealed:** separation of the pumphead and the hydraulic circuit from the lubrication system of the mechanism
- **Multi purposes:** it is employed to dose clean liquids and as well as aggressive liquids or abrasive slurries

Options

- Customized connections
- Detection system (**EFD**) through pressure switch in flame proof execution too
- Cooling or heating jackets containing pumphead body only (**C**) or valves too (**CV**)
- Versions with different materials

Check valves

Check valves are an important component of the pumphead, the precision of a pump depends from their efficiency. There are different types of valves to be selected to meet the characteristics of the medium and the required performance; for high pressure or very low flow rates, double valves are used.

- **Ball check valves:** The most popular check valve is the ball valve, its popularity is given by its availability in many kinds of materials: steel, ceramic, glass, elastomers
- **Wing check valves:** Wing valves find their ideal application with clean liquids and where high accuracy and pressure are
- **Disc valves:** The disc valve, mostly used with high flow rate pumps, has a wide seat opening to allow the passage of the maximum amount of liquid with the minimum opening
- **Slurry valves:** Slurry valves are available for abrasive service, they have high clearances, hardened surfaces and soft seats that prevent the build up of solids. They are designed for slurries such as: slip (potter's clay), diatomite, lime, etc.



SWE1R Exacta Series



Model	50 Hz						60 Hz		SWE1R			
	Strokes /min.	Max. Flow Rate		Strokes /min.	Max. Flow Rate		Max. Pressure		Electric motor	Suc/Dis Connec. Ø BSP		
		l/h	gph		l/h	gph	bar	p.s.i.		kW	STT	PTT
SWE1R 6	74	1,5	0,4	89	1,8	0,47	80	1160	0,55	*1/4" M	3/8" M	
	93	1,9	0,5	112	2,3	0,6	80	1160	0,55	*1/4" M	3/8" M	
	118	2,4	0,6	-	-	-	80	1160	0,75	*1/4" M	3/8" M	
SWE1R 8	74	2,9	0,8	89	3,5	0,9	80	1160	0,55	*1/4" M	3/8" M	
	93	3,7	1,0	112	4,4	1,2	80	1160	0,55	*1/4" M	3/8" M	
	118	4,6	1,6	-	-	-	80	1160	0,75	*1/4" M	3/8" M	
SWE1R 10	74	4,8	1,3	89	5,8	1,5	80	1160	0,55	1/4" M	3/8" M	
	93	6,1	1,6	112	7,3	1,9	80	1160	0,55	1/4" M	3/8" M	
	118	7,6	2,0	-	-	-	80	1160	0,75	1/4" M	3/8" M	
SWE1R 12	74	7,1	1,9	89	8,5	2,3	80	1160	0,55	1/4" M	3/8" M	
	93	9,1	2,4	112	10,9	2,9	80	1160	0,55	1/4" M	3/8" M	
	118	11	2,9	-	-	-	80	1160	0,75	1/4" M	3/8" M	
SWE1R 15	74	11,8	3,1	89	14,2	3,7	80	1160	0,55	1/4" F	3/8" M	
	93	15	4,0	112	18,0	4,8	80	1160	0,55	1/4" F	3/8" M	
	118	18,7	4,9	-	-	-	80	1160	0,75	1/4" F	3/8" M	
SWE1R 26	74	37	9,8	89	44	11,7	80	1160	0,55	1/4" F	3/8" M	
	93	47	12,4	112	56	14,9	80	1160	0,55	1/4" F	3/8" M	
	118	59	15,6	-	-	-	80	1160	0,75	1/4" F	3/8" M	
SWE1R 35	74	77	20,4	89	92	24,4	65	943	0,75	1/2" F	3/8" M	
	93	96	25,4	112	115	30,5	65	943	1,1	1/2" F	3/8" M	
	118	122	32,3	-	-	-	65	943	1,1	1/2" F	3/8" M	
SWE1R 51	74	164	43,4	89	197	52,1	35	508	1,1	1/2" F	1/2" F	
	93	206	54,5	112	247	65,4	35	508	1,1	1/2" F	1/2" F	
	118	261	69	-	-	-	35	508	1,5	1/2" F	1/2" F	
SWE1R 70	74	310	82	89	372	98	18	261	1,1	3/4" F	1" F	
	93	390	103	112	468	124	18	261	1,1	3/4" F	1" F	
	118	495	131	-	-	-	18	261	1,5	3/4" F	1" F	
SWE1R 86	74	471	125	89	565	150	13	189	1,1	1" F	1" F	
	93	592	157	112	710	188	13	189	1,1	1" F	1" F	
	118	751	199	-	-	-	13	189	1,5	1" F	1" F	
SWE1R 99	74	624	165	89	749	198	9	131	1,1	1" F	1" F	
	93	784	207	112	941	249	9	131	1,1	1" F	1" F	
	118	995	263	-	-	-	9	131	1,5	1" F	1" F	
SWE1R 120	74	917	243	89	1100	291	6,5	94	1,1	1 1/4" F	**1 1/4" F	
	93	1153	305	112	1384	366	6	87	1,1	1 1/4" F	**1 1/4" F	
	118	1462	387	-	-	-	6	87	1,5	1 1/4" F	**1 1/4" F	

* Ceramic Valves

** PTFE disc valve

Technical Features

Flow Rate	from 1,5 to 1462 l/h (0,47 to 366 gph)
Pressure	from 80 to 6 bar (1160 to 87 psi)
Stroke rate	74 • 93 • 118 stokes/min. (50Hz) 89 • 112 stokes/min. (60Hz)
Piston diameter	from 6 to 120 mm
Motor Powers	0,55(D) • 0,75(E) 1,1(F) • 1,5(G) kW

The shown pressures refer to rated values.
Available motors (0,55 - 0,75 - 1,1 - 1,5 kW).
For further details please contact our offices.

Model number	(Key to symbols)
SWE1R	Pump model
120	Piston diameter
S	Pump head S=316L or P=PP
T	Membrane T=PTFE
A	(A) Single Valves • (B) Double Valves
24	Reduction ratio (15 • 19 • 24)
4	Motor Poles (2 • 4)
G	Motor Power

Version		Contact parts materials				
Type	Bar max	Pumphead	Diaphragms	Valve Body	Valves	Seats
PTTA	10	PP	PTFE	PP	Pyrex	PTFE
PTTB	10	PP	PTFE	PP	Pyrex	PTFE
STTA	40	316L	PTFE	316L	316L	316L
STTB	80	316L	PTFE	316L	316L	316L
PESP	Plastic special versions					
SESP	Stainless steel special versions					

SWE2 & SWE2DE Exacta Series



Model	50 Hz						60 Hz			SWE2	
	Strokes /min.	Max. Flow Rate		Strokes /min.	Max. Flow Rate		Max. Pressure		Electric motor kW	Suc/Dis Connec. Ø BSP	
		l/h	gph		l/h	gph	bar	p.s.i.		STT	PTT
SWE2 15	70	17	4,5	84	20,4	5,4	80	1160	0,75	1/4" M	3/8" M
	93	23	6,1	112	27,6	7,3	80	1160	0,75	1/4" M	3/8" M
	122	30	7,9	-	-	-	80	1160	0,75	1/4" M	3/8" M
SWE2 25	70	50	13,2	84	60	15,9	80	1160	1,5	1/2" F	3/8" F
	93	66	17,5	112	79	21	80	1160	1,5	1/2" F	3/8" F
	122	86	22,8	-	-	-	80	1160	1,5	1/2" F	3/8" F
SWE2 35	70	107	28,3	84	128	34	80	1160	1,5	1/2" F	3/8" F
	93	144	38,1	112	173	45,7	80	1160	2,2	1/2" F	3/8" F
	122	190	50,3	-	-	-	80	1160	2,2	1/2" F	3/8" F
SWE2 50	70	223	59	84	268	70,8	40	580	1,5	3/4" F	1/2" F
	93	297	78,6	112	356	94,3	40	580	2,2	3/4" F	1/2" F
	122	390	130,2	-	-	-	40	580	2,2	3/4" F	1/2" F
SWE2 70	70	441	116,7	84	529	140	22	319	1,5	1" F	1" F
	93	586	155	112	703	186	17	247	1,5	1" F	1" F
	122	770	203,7	-	-	-	20	290	2,2	1" F	1" F
SWE2 86	70	651	172,2	84	781	206,7	15	218	1,5	1" F	1" F
	93	865	22,8	112	1038	247,6	15	218	2,2	1" F	1" F
	122	1134	300	-	-	-	13	189	2,2	1" F	1" F
SWE2 100	70	904	239,2	84	1085	287	11	160	1,5	1" F	*1 1/4" F
	93	1202	318	112	1442	381,6	11	160	2,2	1" F	*1 1/4" F
SWE2 120	70	1305	345,2	84	1556	414,3	7	102	1,5	1 1/4" F	*1 1/4" F
	93	1732	458,2	112	2048	549,8	7	102	2,2	1 1/4" F	*1 1/4" F
SWE2 140	70	1783	471,7	84	2140	566	5	73	1,5	1 1/2" F	**1 1/2" F
	93	2371	627,2	112	2845	752,7	5	73	2,2	1 1/2" F	**1 1/2" F

SWE2 DE											
SWE2DE 50	70	390	103	84	468	124	29	421	1,1	3/4" F	1/2" F
	93	520	138	112	624	165	29	421	1,1	3/4" F	1/2" F
	122	682	180	-	-	-	29	421	1,5	3/4" F	1/2" F
SWE2DE 70	70	826	219	84	991	262	14	203	1,1	1" F	1" F
	93	1098	290	112	1318	349	14	203	1,1	1" F	1" F
	122	1440	381	-	-	-	14	203	1,5	1" F	1" F
SWE2DE 100	70	1674	443	84	2009	531	7	102	1,1	1" F	*1 1/4" F
	93	2224	588	112	2669	706	7	102	1,1	1" F	*1 1/4" F
	122	2918	772	-	-	-	7	102	1,5	1" F	*1 1/4" F
SWE2DE 140	70	3422	905	84	4106	1086	3,5	51	1,1	1 1/2" F	**1 1/2" F
	93	4547	1203	112	5456	1443	3,5	51	1,1	1 1/2" F	**1 1/2" F
	122	5964	1578	-	-	-	3,6	52	1,5	1 1/2" F	**1 1/2" F
SWE2DE 200	70	7137	1888	84	8564	2266	1,8	26	1,1	2" F	**2" F
	93	9484	2509	112	11381	3011	1,8	26	1,5	2" F	**2" F

* PTFE disc valve

** PP ball valve

The shown pressures refer to rated values.
Available motors (0,75 - 1,1 - 1,5 - 2,2 kW).
 For further details please contact our offices.

Technical Features

Flow Rate	from 20 to 9484 l/h (6,3 to 3011 gph)
Pressure	from 80 to 6 bar (1160 to 87 psi)
Stroke rate	70 • 93 • 122 stokes/min. (50Hz) 84 • 112 stokes/min. (60Hz)
Piston diameter	from 15 to 200 mm
Motor Powers	0,75(E) • 1,1(F) 1,5(G) • 2,2(H) kW

Model number (Key to symbols)

SWE1R	Pump model
200	Piston diameter
S	Pump head S=316L or P=PP
T	Membrane T=PTFE
A	(A) Single Valves • (B) Double Valves
24	Reduction ratio (15 • 20 • 23)
4	Motor Poles (2 • 4)
H	Motor Power

Version		Contact parts materials				
Type	Bar max	Pumphead	Diaphragms	Valve Body	Valves	Seats
PTTA	10	PP	PTFE	PP	Pyrex	PTFE
PTTB	10	PP	PTFE	PP	Pyrex	PTFE
STTA	40	316L	PTFE	316L	316L	316L
STTB	80	316L	PTFE	316L	316L	316L
PESP	Plastic special versions					
SESP	Stainless steel special versions					

SWE3 & SWE3DE Exacta Series

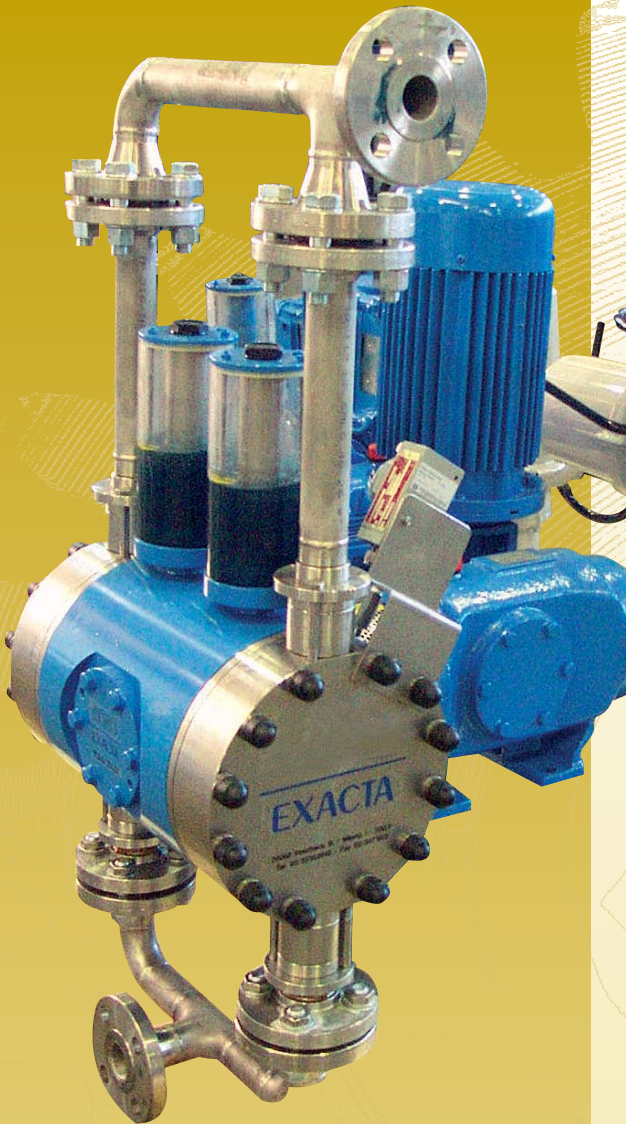

Model	50 Hz						60 Hz		SWE3			
	Strokes /min.	Max. Flow Rate		Strokes /min.	Max. Flow Rate		Max. Pressure		Electric motor	Suc/Dis Connec. Ø BSP		
		l/h	gph		l/h	gph	bar	p.s.i.		kW	STT	PTT
SWE3 25	70	89	23,5	84	107	28,3	80	1160	2,2	1/4" F	3/8" F	
	93	118	31,2	112	142	37,5	80	1160	2,2	1/4" F	3/8" F	
	122	156	41,3	-	-	-	80	1160	3	1/4" F	3/8" F	
SWE3 35	70	178	47,1	84	214	56,5	80	1160	2,2	1/2" F	1/2" F	
	93	236	62,4	112	283	75	80	1160	3	1/2" F	1/2" F	
	122	310	82	-	-	-	80	1160	4	1/2" F	1/2" F	
SWE3 50	70	371	98	84	445	118	80	1160	4	1" F	1" F	
	93	493	130	112	592	185	80	1160	5,5	1" F	1" F	
	122	648	171	-	-	-	80	1160	7,5	1" F	1" F	
SWE3 70	70	735	194	84	882	233	51	740	5,5	1" F	1" F	
	93	977	258	112	1172	310	52	754	7,5	1" F	1" F	
	122	1281	339	-	-	-	40	580	9,2	1" F	1" F	
SWE3 86	70	1090	288	84	1308	346	37	537	7,5	1 1/4" F	*1 1/4" F	
	93	1448	383	112	1738	460	35	508	7,5	1 1/4" F	*1 1/4" F	
	122	1900	503	-	-	-	33	479	9,2	1 1/4" F	*1 1/4" F	
SWE3 100	70	1551	400	84	1831	480	26	377	7,5	1 1/4" F	*1 1/4" F	
	93	2007	531	112	2408	637	25	363	7,5	1 1/4" F	*1 1/4" F	
SWE3 120	70	2177	576	84	2612	691	18	261	7,5	1 1/2" F	**1 1/2" F	
	93	2893	765	112	3472	918	18	261	7,5	1 1/2" F	**1 1/2" F	
SWE3 140	70	2967	785	84	3560	942	13	189	5,5	1 1/2" F	**1 1/2" F	
	93	3942	1043	112	4730	1251	13	189	7,5	1 1/2" F	**1 1/2" F	

SWE3 DE											
SWE3DE 50	70	657	174	84	788	209	40	580	2,2	1" F	1" F
	93	873	231	112	1048	277	40	580	3	1" F	1" F
	122	1146	303	-	-	-	40	580	4	1" F	1" F
SWE3DE 70	70	1387	367	84	1664	440	40	580	4	1" F	1" F
	93	1836	486	112	2203	583	40	580	5,5	1" F	1" F
	122	2419	640	-	-	-	40	580	7,5	1" F	1" F
SWE3DE 100	70	2806	742	84	3367	891	24	348	5,5	1 1/4" F	*1 1/4" F
	93	3728	986	112	4474	1183	21	305	5,5	1 1/4" F	*1 1/4" F
	122	4891	1294	-	-	-	21	305	7,5	1 1/4" F	*1 1/4" F
SWE3DE 140	70	5741	1519	84	6889	1823	11	160	5,5	1 1/2" F	**1 1/2" F
	93	7628	2018	112	9541	2422	11	160	7,5	1 1/2" F	**1 1/2" F
SWE3DE 200	70	11917	3167	84	14365	3800	5,4	78	5,5	2 1/2" F	**2 1/2" F
	93	15906	4208	112	19087	5050	5,4	78	7,5	2 1/2" F	**2 1/2" F

* PTFE disc valve ** PP ball valves

Technical Features

Flow Rate	from 89 to 15906 l/h (23,5 to 5050 gph)
Pressure	from 80 to 6 bar (1160 to 87 psi)
Stroke rate	70 • 93 • 120 stokes/min. (50Hz) 84 • 112 stokes/min. (60Hz)
Piston diameter	from 25 to 200 mm
Motor Powers	2,2(H) • 3(I) • 4(J) 5,5(K) • 7,5(L) • 9,2(N) kW

The shown pressures refer to rated values.
Available motors (2,2 - 3 - 4 - 5 - 7,5 - 9,2 kW).
For further details please contact our offices.

Model number	(Key to symbols)
SWE3	Pump model
200	Piston diameter
S	Pump head S=316L or P=PP
T	Membrane T=PTFE
A	(A) Single Valves • (B) Double Valves
24	Reduction ratio (15 • 20 • 23)
4	Motor Poles (2 • 4)
N	Motor Power

Version		Contact parts materials				
Type	Bar max	Pumphead	Diaphragms	Valve Body	Valves	Seats
PTTA	10	PP	PTFE	PP	Pyrex	PVC
PTTB	10	PP	PTFE	PP	Pyrex	PVC
STTA	40	316L	PTFE	316L	316L	316L
STTB	80	316L	PTFE	316L	316L	316L
PESP	Plastic special versions					
SESP	Stainless steel special versions					

Dimensional drawings and selection table

Model	Flow Rate (l/h)		Pressure (bar)		Dimensions (mm)*			Kg*
	min	max	min	max	E**	H	G	
SWE1R	1,5	1462	6	80	538÷638	330	192	13÷60
SWE2	20	2371	5	80	650÷715	350	232	24÷40
SWE2DE	390	9484	1,8	27	750÷850	350	232	69÷130
SWE3	89	3942	13	80	910÷943	500	357	100÷154
SWE3DE	657	15906	5,4	40	950÷1090	500	357	116÷165

* Without Electric motor, depending on pumphead size

** Depending on pump head size

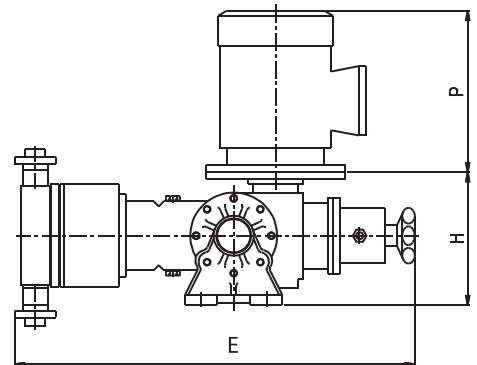
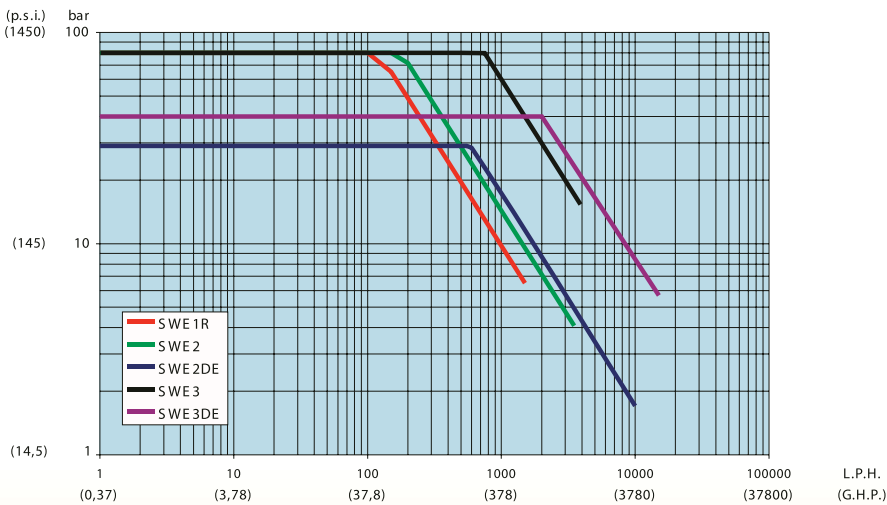
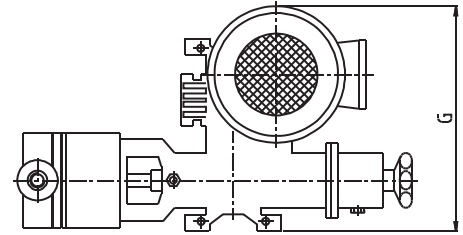

Accessories for the correct installation

The trouble-free operation of a pump depends mainly by an installation studied for the required duty; the choice of the suitable accessories and their sizing are very important to fit the pump in a functional system.



Filters

Liquids may contain impurities that can cause the malfunctioning of the valves and consequently flow fluctuation and even the clogging of the pipes. To prevent these dangerous situations it is advisable to install a filter on the suction line; the filter should be correctly sized to limit pressure losses in critical suction installations.

Safety valves

Safety valves are installed to prevent dangerous situations in case of unexpected overpressure that can damage the pump and the pipes. Metering pumps are positive displacement pumps that can reach high pressures in one stroke, therefore they should be protected by possible clogging of the pipes provoked by sedimentation or accidental closure of a valve. Hydraulic diaphragm pumps are protected with a limiting pressure valve built-in in the hydraulic circuit; the piping should be protected by an in-line pressure safety valve.

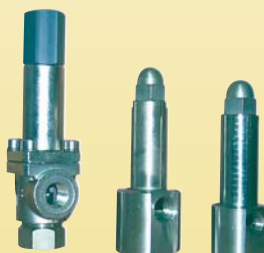

Back pressure valves

To allow the correct operation of a pump and to prevent the flow-through (siphoning) of the process liquid, the discharge pressure should be greater than the suction pressure; when this condition is not respected then a backpressure valve can be the solution.



Pulsation dampers

The reciprocating movement of the piston generates pulsations: during each stroke the liquid contained in the suction and discharge lines is accelerated from zero to the maximum speed and then decelerated to zero again. Pulsation dampers are the accessories suggested to reduce high and not permissible pressure fluctuations or to obtain a linearity of the flow. A similar result can be obtained by using a multiheaded dosing group which is more expensive.



Calibration pots

The calibration pot installed on the suction line gives the possibility to check the actual flow rate of a metering pump in the real operating conditions. The capacity of the calibration pot should be as to permit a measurement during 30 seconds approx; the calibration pot should be installed in vertical position near the pump and should be fitted with check valve to simplify the use.





SEKO
www.seko.com



SEKO do Brasil **BRAZIL** • SEKO China **CHINA** • SEKO France **FRANCE** • SEKO Deutschland **GERMANY** • SEKO Italia **ITALY**
 OOO SEKO **RUSSIA** • SEKO Asia Pacific **SINGAPORE**
 SEKO Southern Africa **SOUTH AFRICA** • SEKO Iberica **SPAIN**
 SEKO UK **UNITED KINGDOM** • SEKO Dosing Systems **USA**

